

GENERAL CHARACTERISTICS

Nominal Overall Diameter	307	mm
Nominal Voice Coil Diameter	50	mm
Magnet Weight	1100	g
Flux Density.....	1.10	T
Total Weight.....	3.60	Kg

THIELE-SMALL PARAMETERS

Voice Coil DC Resistance	R_E	6.88	Ω
Resonance Frequency	f_s	87.5	Hz
Mechanical Q Factor.....	Q_{MS}	18.74	
Electrical Q Factor.....	Q_{ES}	0.61	
Total Q Factor	Q_{TS}	0.59	
Mechanical Moving Mass	M_{MS}	29.6	g
Mechanical Compliance	C_{MS}	112	μm/N
Force Factor	$B \times l$	13.53	Wb/m
Equivalent Acoustic Volume.....	V_{AS}	37.8	lt.
Maximum Linear Displacement	X_{MAX}	1.0	mm
Reference Efficiency	η_0	3.98	%
Diaphragm Area	S_D	490.8	cm ²
Losses Electrical Resistance.....	R_{ES}	210.5	Ω
Voice Coil Inductance @ 1kHz	L_E	0.92	mH

CONSTRUCTIVE CHARACTERISTICS

Magnet.....	Ferrite
Voice Coil Winding.....	Copper
Voice Coil Former.....	Nomex
Cone	Paper
Surround.....	Integrated Paper
Dust Dome	Non Treated Cloth
Basket	Pressed Sheet Steel

ELECTRICAL CHARACTERISTICS

Nominal Impedance.....	8	Ω
Rated Power (DIN 45573 - IEC 268.5)	110	W
Musical Power (DIN 45500)	220	W
Sensitivity @ 1 W, 1 m	98.7	dB

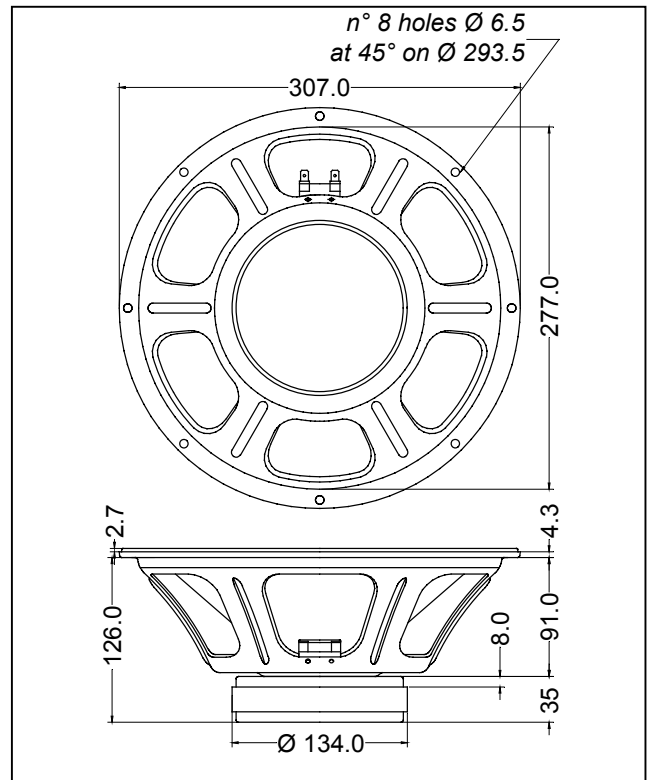

Frequency Response on IEC Baffle (DIN 45575) @ 1 W, 1 m - Impedance

