

### GENERAL CHARACTERISTICS

Nominal Overall Diameter .....	259	mm
Nominal Voice Coil Diameter .....	25	mm
Magnet Weight .....	270	g
Flux Density.....	1.10	T

### THIELE-SMALL PARAMETERS

Voice Coil DC Resistance .....	$R_E$	3.30	Ω
Resonance Frequency .....	$f_s$	107.0	Hz
Mechanical Q Factor.....	$Q_{MS}$	15.65	
Electrical Q Factor.....	$Q_{ES}$	1.58	
Total Q Factor.....	$Q_{TS}$	1.44	
Mechanical Moving Mass .....	$M_{MS}$	15.2	g
Mechanical Compliance.....	$C_{MS}$	146.0	μm/N
Force Factor .....	$B \times l$	4.67	Wb/m
Equivalent Acoustic Volume.....	$V_{AS}$	22.4	lt.
Maximum Linear Displacement ...	$X_{MAX}$	1.0	mm
Reference Efficiency .....	$\eta_0$	1.65	%
Diaphragm Area .....	$S_D$	330.0	cm <sup>2</sup>
Losses Electrical Resistance.....	$R_{ES}$	34.0	Ω
Voice Coil Inductance @ 1kHz .....	$L_E$	0.31	mH

### CONSTRUCTIVE CHARACTERISTICS

Magnet.....	Ferrite
Voice Coil Winding.....	Copper
Voice Coil Former.....	Epotex
Cone .....	Paper
Surround.....	Integrated Paper
Dust Dome .....	Non Treated Cloth
Basket .....	Pressed Sheet Steel

### ELECTRICAL CHARACTERISTICS

Nominal Impedance.....	4	Ω
Rated Power (DIN 45573 - IEC 268.5) .....	35	W
Musical Power (DIN 45500) .....	70	W
Sensitivity @ 1 W, 1 m .....	94.9	dB

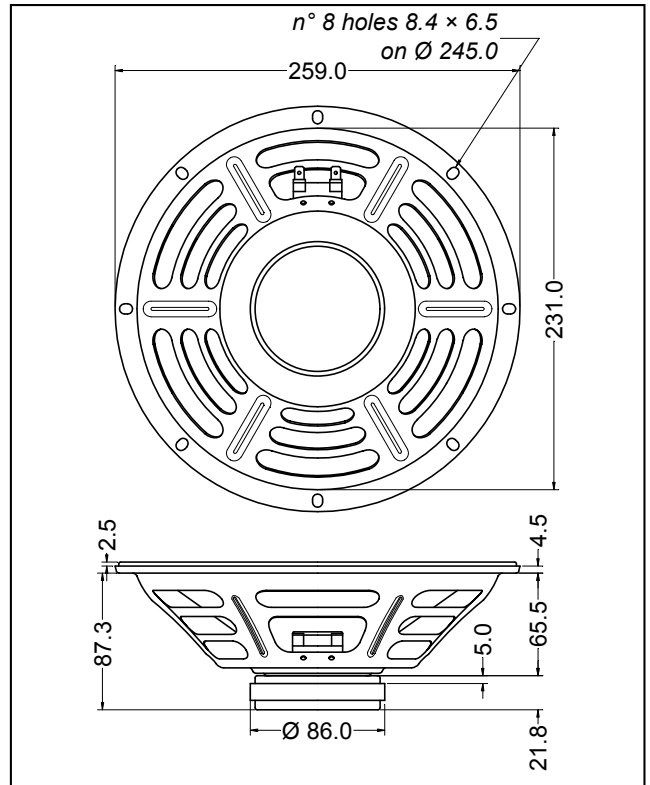

Frequency Response on IEC Baffle (DIN 45575) @ 1 W, 1 m -

Impedance

